



# Big Bakers Oven

## Installation Instructions



Pecan Engineering Pty Ltd  
13 Acorn Road  
Dry Creek  
South Australia 5094  
Email [info@pecan-eng.com.au](mailto:info@pecan-eng.com.au)  
Phone: (08) 8349 8332  
Fax: (08) 8260 6643

**THE INSTALLATION INSTRUCTIONS IN THIS  
MANUAL APPLY TO THE  
NECTRE BIG BAKERS OVEN.**

## 1. INTRODUCTION

Most building regulatory Authorities in Australia require any wood heater installation to comply with Installation Standard AS/NZS 2918:2001. Different states and councils may have varying regulations. Check local building regulations before installing the appliance.

All Nectre wood heaters have been tested to ensure that they will meet the appropriate safety Standard requirements if the instructions in this manual are followed. As the safety and emissions performance can be affected by altering the appliance, no modifications are allowed without written permission from the manufacturer.

**WE RECOMMEND THAT THE INSTALLATION OF YOUR NECTRE WOOD HEATER BE CARRIED OUT BY A QUALIFIED INSTALLER.**

**WARNING: THE APPLIANCE AND FLUE SYSTEM SHALL BE INSTALLED IN ACCORDANCE WITH AS/NZS 2918:2001 AND THE APPROPRIATE REQUIREMENTS OF THE RELEVANT BUILDING CODE OR CODES.**

**ANY MODIFICATION OF THE APPLIANCE THAT HAS NOT BEEN APPROVED IN WRITING BY THE TESTING AUTHORITY IS CONSIDERED TO BE IN BREACH OF THE APPROVAL GRANTED FOR COMPLIANCE WITH AS/NZS 4012 & AS/NZS 4013.**

**CAUTION: MIXING OF APPLIANCE OR FLUE-SYSTEM COMPONENTS FROM DIFFERENT SOURCES OR MODIFYING THE DIMENSIONAL SPECIFICATION OF COMPONENTS MAY RESULT IN HAZARDOUS CONDITIONS. WHERE SUCH ACTION IS CONSIDERED, THE MANUFACTURER SHOULD BE CONSULTED IN THE FIRST INSTANCE.**

**CAUTION: CRACKED AND BROKEN COMPONENTS, EG. GLASS PANELS OR CERAMIC TILES, MAY RENDER THE INSTALLATION UNSAFE.**

## 2. INSTALLING THE HEATER

### 2.1 Positioning the Heater

First review the necessary clearances specified below before considering where to position the heater.

Also check the practicability of installing the flue system in relation to any obstructing roof beams before positioning the heater.

These clearance distances can only be reduced if the surrounding walls are made of non-combustible material, eg. Stone, brick, or concrete. If non-combustible material, distance can be reduced to 100 mm. Alternatively, shielding of the wall(s) can reduce clearances (refer to next section for more detail).

#### 2.1.1 Standard Installation:

- Rear wall clearance – 125 mm
- Side wall clearance – 325 mm

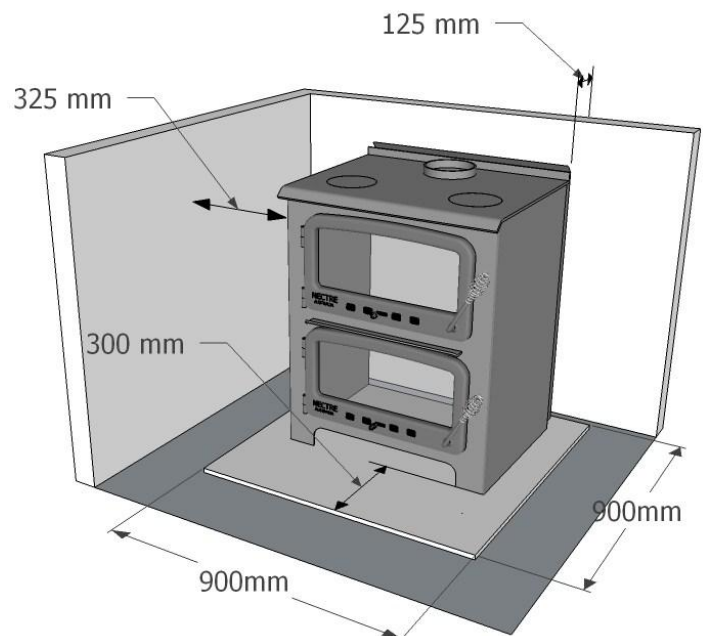

### 2.1.2 Corner Installation:

- Corner to wall clearance – 275 mm

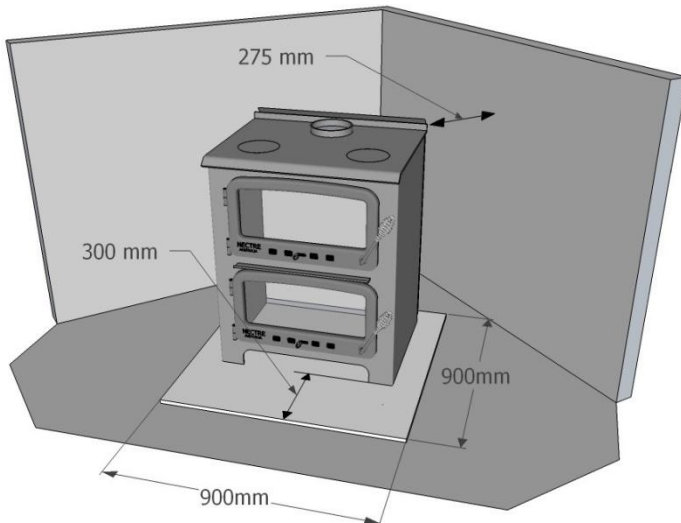

## 2.2 Floor Protector (Hearth)

Unless the heater will be standing on a heat resistant floor such as concrete slab with slate or tiles, it will be necessary to provide a floor protector (hearth).

The dimensions given in above (Section 2.1) are the minimum required for the floor protector. It must extend no less than 300 mm in front of the door opening. It may be desirable, for example aesthetic reasons, for the floor protector to be larger than these minimum dimensions.

The floor protector shall be constructed of non-combustible material no less than 15mm thick and with a thermal conductivity not greater than  $0.33\text{W/m}^{\circ}\text{K}$ , eg. compressed cement sheet. The floor protector may be laid directly on the combustible floor.

For more details and variations on floor protectors refer to AS/NZS 2918:2001 Clause 2.2, 3.3.1, & 3.3.2.

## 3. Reducing Clearances to Combustible Walls

If it is necessary to install a heater closer to a combustible surface than the stated requirements in Section 2 of this Installation Guide, it must be done in accordance with Australian Standard AS/NZS 2918:2001 Section 3, Tables 3.1 & 3.2.

**Shield Construction:-** The shield shall be constructed from a heat resistant material. The shield must be fixed to the surface that requires protection and NOT the heater.

The Standard allows three options to reduce stated clearances.

Single layer of continuous material with Minimum Air Gap of 12mm—Clearance Factor = 0.40

Single layer of continuous material with Minimum Air Gap of 25mm—Clearance Factor = 0.30

Two spaced layers of continuous material with Minimum Air Gaps of 12mm + 12mm—Clearance Factor = 0.20

The shielding must be open at the top and bottom (vented) to allow a continuous air flow. It is this air flow that keeps the surface requiring protection cool. Fixings should not impede this air flow.

The shielding needs to go far enough along and up the wall so that the original side and rear required clearances are not compromised. As the flue is now closer to the wall the shielding should also protect the wall from the flue pipe.

### For example:

Side wall clearance for the Big Bakers Oven is 325 mm.

A 12mm gapped shield on the wall with a factor of 0.40.

Calculate:-  $325\text{ mm} \times 0.40 = 130\text{ mm}$ . This is the new side wall minimum clearance.

The shielding needs to be large enough so that none of the original clearances of 325 mm are compromised.

#### 4. INSTALLING THE BY-PASS DAMPER

Before installing the flue, the by-pass damper handle must be fitted. The handle is supplied inside the firebox.

Insert the threaded end of the handle into the 10mm hole on left side of heater. Looking down through the flue spigot locate the threaded end of the handle with the extended nut attached to the by-pass damper. Screw the handle all the way into the nut until tight.

The position of the handle should be at approximately 11 o'clock when the damper is open, and 1 o'clock when the damper is shut.

#### 5. INSTALLING THE FLUE

The flue system used when installing the heater **MUST** comply with the current installation standard AS/NZS 2918.

Full instructions on the installation of the flue will be supplied with the flue kit. These **MUST** be followed closely, including the minimum exit height from the top of the floor protector being not less than 4.6m, and the minimum exit height above the roof line of roof ridge as detailed in the instructions.

The flue must be fitted with a 900 mm long, minimum 150° arc, stainless steel rear flue shield.

If the draft is insufficient or periodic down drafting occurs and the heater smokes or only burns slowly, extending the flue or fitting a specialist cowl will usually resolve the issue.

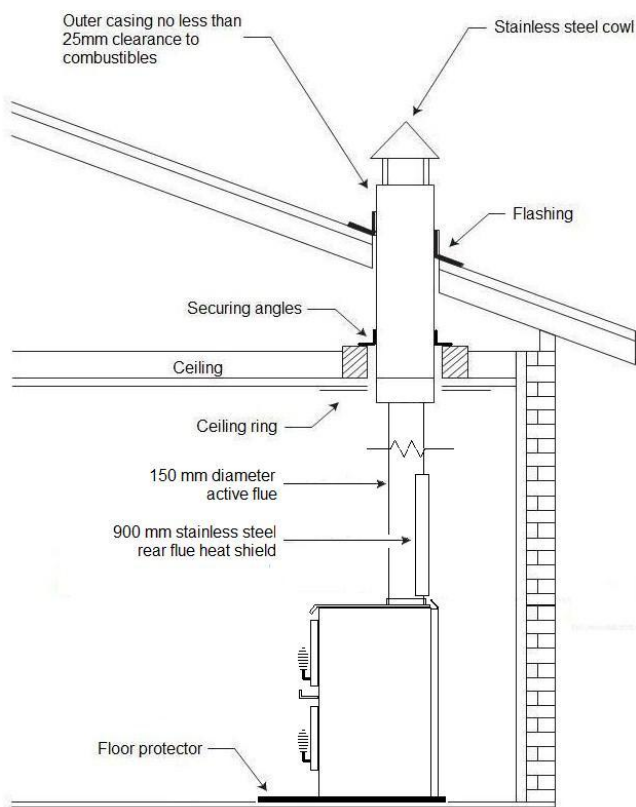

#### 6. INSTALLING FIRE BRICKS

The heater comes with 4 fire bricks (230 mm x 115 mm x 38 mm) and a 480 mm long brick retainer as well as two triangular bricks (50 x 70 x 250 mm) for the front.

Place the four fire bricks upright, up against the rear wall of the firebox.

Place the U-shaped brick retainer over the top of the bricks such that the bricks fit inside the U-section. This will hold them in place.

Place the triangular firebricks at the front of the firebox beneath the door opening.

(Note: the firebricks may already be in place upon arrival of the new appliance.)

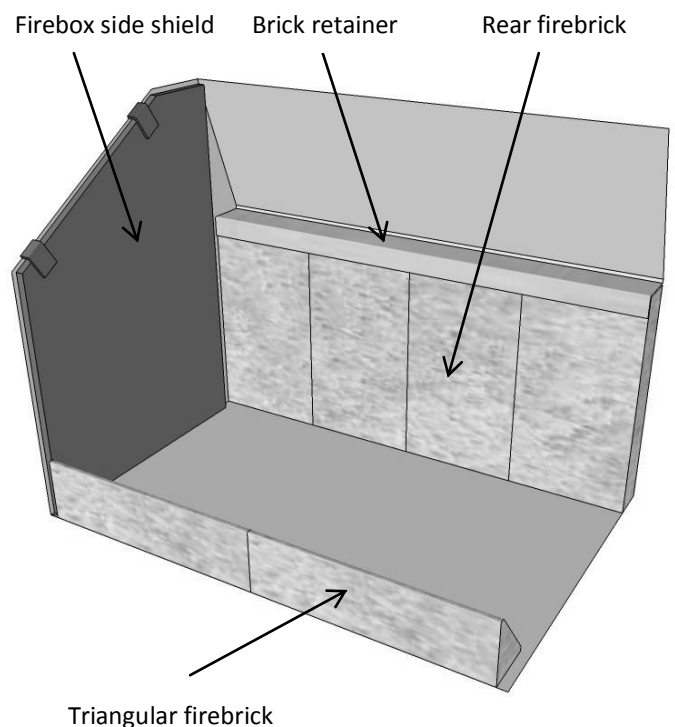

#### 7. INSTALLING FIREBOX SIDE SHIELDS

The heater comes with two 8 mm thick sacrificial shields fitted to the sides of the firebox to protect the walls of the firebox.

Lugs on the shields allow them to hang over the angled cut-out on the sides of the firebox along the top.

(Note: the firebox side shields may already be in place upon arrival of the new appliance).

## 8. INSTALLING BAFFLE PLATE

The heater comes with a 250 (d) x 325 (w) x 6 (h) mm baffle plate. This rests on the two lugs welded to the inside front of the firebox and on the brick retainer at the back of the heater.

Position the baffle plate vertically towards the rear of the firebox with the 100mm strip welded to the baffle at the top facing forward. Bring the top edge towards the front of the heater so that it slides up and over the two support lugs with the 100mm strip located between them. Raise the lower rear edge of the baffle plate to rest on top of the brick retainer.

With the baffle plate in its correct position, ensure it is pushed all the way back so that it doesn't fall.

## 9. INSTALLING TOP AIR CONTROL ROD

A stainless steel rod with a thread at one end and black knob on the other will have been supplied in the heater. Pass the threaded end of the rod through the hole near the top front corner on the left side of the heater. Push the rod through until one can feel it has located the nut on the air slide, then screw rod until tight. Check that the rod slides freely back and forth.

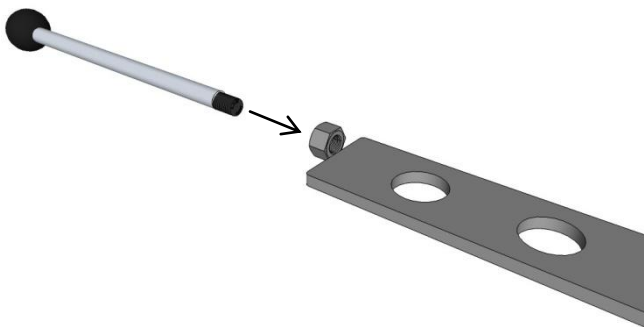

## 10. TECHNICAL DRAWINGS

Front view:-

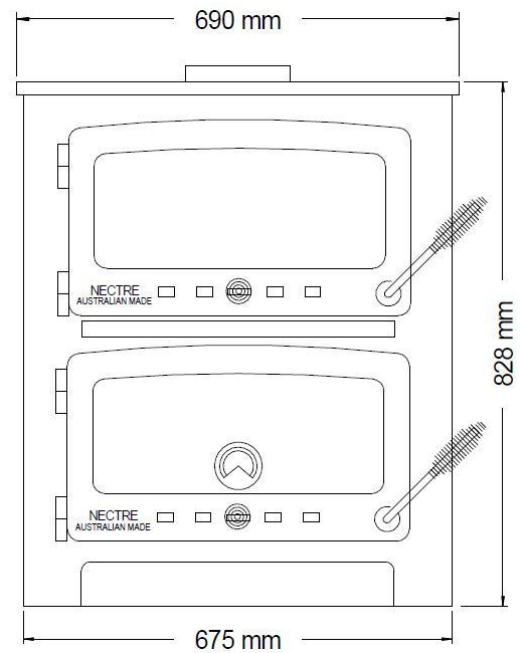

Front view:-

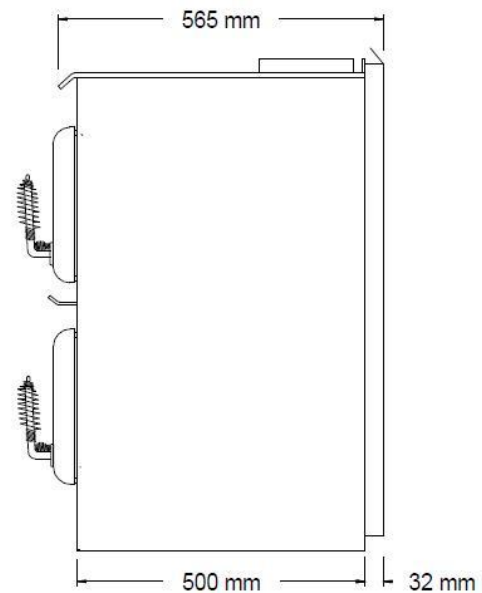

Top view showing position of flue spigot:-

